

Suppressor and LED Indicators for PS1E

Mount between Solenoid Valve and the Interface Module

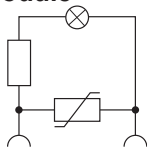

Circuit Diagram



PS1E1620●

Characteristics	Voltage	Part Number	Weight	
			lb	kg
Indication by LED Sold in Lots of 5	24 VDC and 50/60 Hz	P8V-CR26C	.022	0.010
	48 VDC and 50/60 Hz	P8V-CR26D	.022	0.010
	120 V / 60 Hz 115 V / 50 Hz	P8V-CR24F	.028	0.012

35mm DIN Rail

AM1DE200	6 Feet
----------	--------

Zinc chromated steel rail for easy mounting of stacks.

DIN rail can be mounted to grids or other surfaces to allow snap in mounting of pneumatic and electrical components.

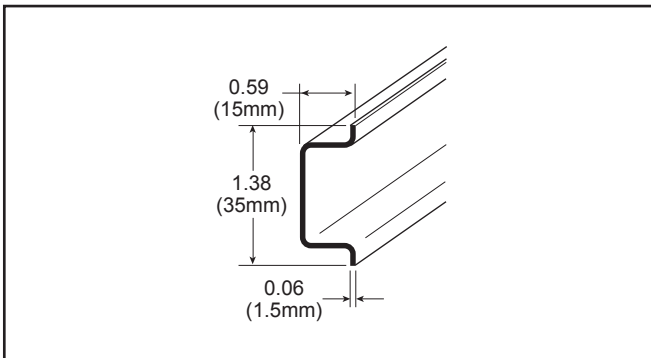

Spare Parts

Description	Part Number
1 lot of 100 O-ring Seals Between Modules (Pressure - Exhaust)	PPR-L12
1 lot of 50 Seals Between Modules 3/2 or 4/2 and Coil PS1-E23 - 25 Seals (Type A) for Modules 3/2 and 4/2 Bistable - 25 Seals (Type B) for Modules 4/2 Monostable and Bistable	PPR-L13

Marking Accessories

To be used in place of Write-On Marking Tabs



AB1-G●

Clip-On Marker Strips	Part Number
Strip of 10 Identical Numerals (State the Number required)	AB1-R●
Strip of 10 Identical Letters (State the Letter required)	AB1-G●
Strip of 10 - Signs*	AB1-R13

*Sold in Lots of 25 Strips of 10 Markers

